

British 'L' Class Destroyer H.M.S. Laforey 1943

Resin & Photo Etched Metal Kit in 1/350 scale

History

HMS Laforey was laid down on 1st March 1939 at Yarrow Shipbuilders Ltd, Scotstoun, Scotland, and launched on the 15th February 1941.
Laforey was immediately sent to join Force H in the Mediterranean and helped to escort the Malta convoys, and was involved in most of the Malta operations during 1941 and 1942.
Laforey was on the scene to help with the rescue of the crew of HMS Ark Royal, after she had been torpedoed off Gibraltar in November 1941. In similar incident Laforey was involved with the rescue of survivors from HMS Eagle in August 1942.
Laforey took part in the shore bombardments of Tunisia in the spring of 1943, then of Pantellaria and Lampedusa in June 1943, and a month later participated in the landings in Sicily.
In July 1943, HMS Laforey and HMS Eclipse sank the Italian submarine Ascianghi with depth charges near Augusta, then took part in the Salerno landings in the September. Between October 1943 and January 1944 Laforey was involved in several shore bombardments on the west coasts of Italy.
On 29th of March 1944 whilst operating with the 14th Flotilla on anti submarine sweep, the U223 was located and heavily depth charged and eventually brought to the surface on the morning of the 30th. U223 managed to fire a Gnat before being sunk, which struck Laforey in a magazine. Laforey sunk immediately with the loss of 189 lives including the C.O of the 14th Flotilla, Captain H.T. ('Beaky') Armstrong DSO DSC.

Specifications

Length: 362ft 6in oa. Beam: 37ft Displacement: 2040 tons light 2725 tons deep. Speed: 34 knots max

Armament: 6 x 4.7inch QF guns in a twin 50° WP mounting MkXX. 4 x 21inch Torpedo Tubes in one quadruple mounting.
42 Depth Charges from 2 stern rails and 2 Mk 11 depth charge throwers. 1 x 4 barrelled 2 pounder Pom Pom.
6 x 20mm Single Oerlikon mountings. 1 x Single 4inch HA/LA gun mounting.

Resin and Metal Parts Identification

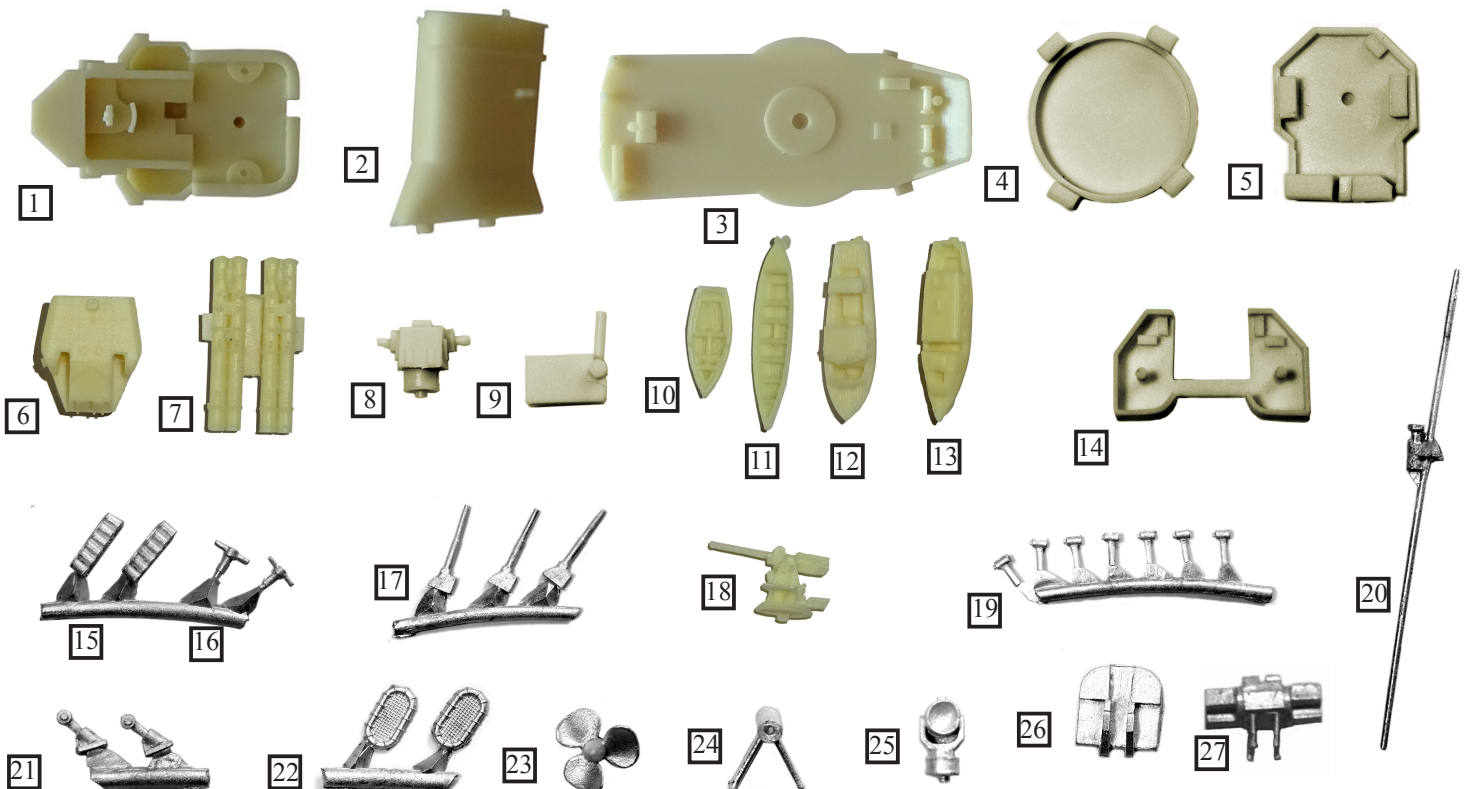

- | | | |
|------------------------------------|--------------------------------|---------------------------------------|
| 1. Bridge Superstructure | 10. 14' Sailing Dinghy | 19. Depth Charge Thrower Reloads x 14 |
| 2. Funnel | 11. 27' Whaler | 20. Fore Mast Pole with Crows Nest |
| 3. Aft Superstructure | 12. 25' Fast Motor Boat | 21. Depth Charge Throwers x 2 |
| 4. Single 4" Gun Platform | 13. 25' Admiralty Motor Cutter | 22. Carley Rafts x 8 |
| 5. Pom Pom Platform | 14. 20mm Oerlikon Platform | 23. Propellers x 2 |
| 6. 4.7" Twin Gun Turret | 15. Depth Charge Chutes x 2 | 24. Propeller A Frame x 2 |
| 7. Quad 21" Torpedo Tubes | 16. Bridge Rangefinders x 2 | 25. Searchlight |
| 8. Director Control Tower (DCT) | 17. 4.7" Gunn Barrels | 26. 4 Barrelled Pom Pom Footplate |
| 9. Wireless House & Galley Chimney | 18. 4" Single HA Gun Mounting | 27. 4 Barrelled Pom Pom Cluster |

General Precautions

When assembling a Resin / Photoetched metal kit, certain precautions must first be taken.

1. Resin dust can be harmful if inhaled. It is recommended that you wear a suitable dust mask when drilling or sanding resin parts.
2. Cyano adhesives (super glues) are generally used to assemble this type of kit. Care must be taken when using this type of adhesive as it will bond in seconds. Follow the advice on the container.
3. Wash resin parts in a solution of warm soapy water before assembly. This will remove any residual mold release agents and ensure a good key for painting.
4. Soak photoetch parts in a suitable solvent, such as white spirit, to degrease the surfaces prior to painting.

Photo Etched Parts Identification

ATLANTIC MODELS © 2023

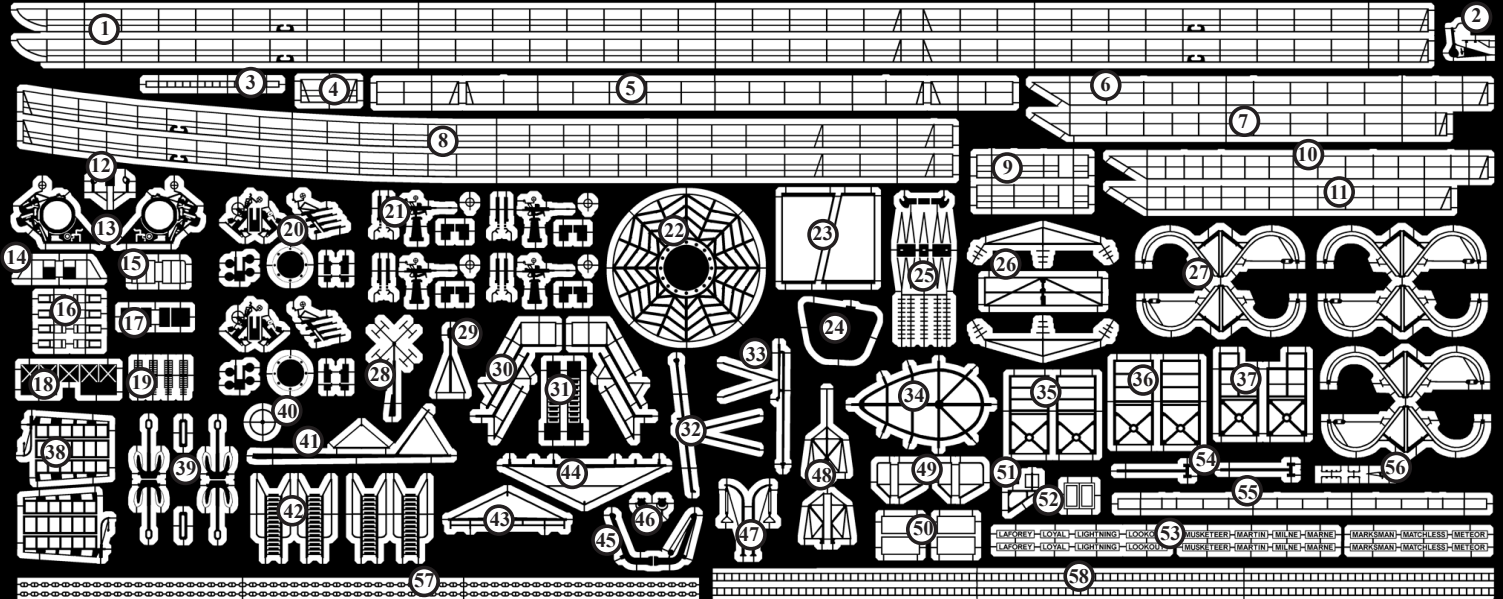

British L & M Class Destroyers 1/350

- | | | | |
|---|---|---|--|
| <ol style="list-style-type: none"> 1. Railings (Main Deck) 2. 25' Admiralty Motor Cutter Parts 3. Bridge Windscreen 4. Railings (Stern) 5. Railings 'B' Gun Deck 6. Railings (X Gun Deck Port) (L) 7. Railings (X Gun Deck Stbd) (L) 8. Railings (Fo'c'sle) 9. Railings (Hull Step) 10. Railings (X Gun Deck Port) (M) 11. Railings (X Gun Deck Stbd) (M) 12. Funnel Sires 13. 4 Barrelled Pom Pom Sides Plates 14. 4 Barrelled Pom Pom Rear Rails 15. 4 Barrelled Pom Pom Front Rails | <ol style="list-style-type: none"> 16. 4 Barrelled Pom Pom Ammo Trays 17. 4 Barrelled Pom Pom Splinter Shield 18. 4 Barrelled Pom Pom Rear Shield 19. 4 Barrelled Pom Pom Ammo Belts 20. 0.5" Quad Vickers MG Assembly 21. 20mm Oerlikon Single Mounting 22. 4" HA Single Gun Footplate 23. Fore Mast Tripod Spacers 24. Rudder 25. 285 Radar Yagi Antenna Array 26. 286 Radar Antenna Array 27. Boat Davits 28. 291 Air Warning Radar Antenna 29. Aft Stove Pipe 30. Accommodation Ladder Handrails | <ol style="list-style-type: none"> 31. Accommodation Ladder Steps 32. Ensign Staff 33. Jack Staff 34. Funnel Cap Grill 35. Carley Raft Racks (Aft) 36. Carley Raft Racks (Midships) 37. Carley Raft Racks (Forward) 38. Depth Charge Rails 39. Anchors 40. Searchlight Lens Cross 41. Main Mast (M Class) 42. Inclined Ladders 43. Fore Mast Yardarm Upper 44. Fore Mast Yardarm Lower 45. Torpedo Loading Davit | <ol style="list-style-type: none"> 46. Signal Lamps 47. Depth Charge Thrower Davits 48. MF/DF Antenna 49. Funnel Siren Platform Rails 50. Boiler Room Vent Grills 51. Bridge Front DF Antenna 52. Forward Vent Grill 53. Ships Name Plates 54. Stove Pipes 55. Pom Pom Platform Handrail 56. 25' Fast Motor Boat Parts 57. Anchor Chain 58. Vertical Ladder Stock |
|---|---|---|--|

General Instructions for working with Photo Etched Metal

1. Do not remove the etched parts from the fret until you are ready to use them.
2. Before assembly, soak the etched parts in a suitable solvent, such as white spirit, to de-grease the surfaces for painting.
3. Cyanoacrylate adhesive (Super glue) or contact adhesive such as Elmers white glue may be used. These can be applied with a pin or piece of stretched sprue.
4. When removing parts from the fret, place the fret on a hard surface, such as a smooth ceramic tile, in order to prevent parts bending whilst cutting through the holding tabs. It is suggested that a #11 type of modelling knife blade is used for this purpose.
5. When shaping or bending a part, a straight edged blade such as a chisel blade #17 or # 18 will give a good sharp corner, or alternatively a small pair of smooth jawed pliers may be used.
6. If a part is bent incorrectly, lay it on a hard flat surface and roll it flat with a cylindrical object such as a modelling knife handle.
7. It is suggested that rails are pre-measured, where practical, using a pair of compass dividers and then tacked to the deck edge every third or fourth stanchion with a small drop of glue. When a section is complete, run a thin line of glue along the inside edge to attach it firmly to the deck.

General Instructions

1. Tailored to fit railings have been provided in this kits photo etched parts fret. These have their locations named in the parts list and are shaped to fit to the edges of the decks designated.
2. Ships name plates, etched parts 53, have been provided for all the 4.7" Gun ships of the class. The name plates are located on each side of the aft superstructure half way up below the gun arc overhang.
3. The assemblies for the Quad Vickers machine gun mountings have been provided as etched parts 20. These are fitted on the lower signal platforms below the bridge of earlier fit ships if an alternative ship is being modelled.
4. Stock lengths of Vertical Ladder have been provided as etched parts 58. This may be cut to the length required to fit to the various superstructure sides, masts or platforms as required.

Main Parts Location Diagram

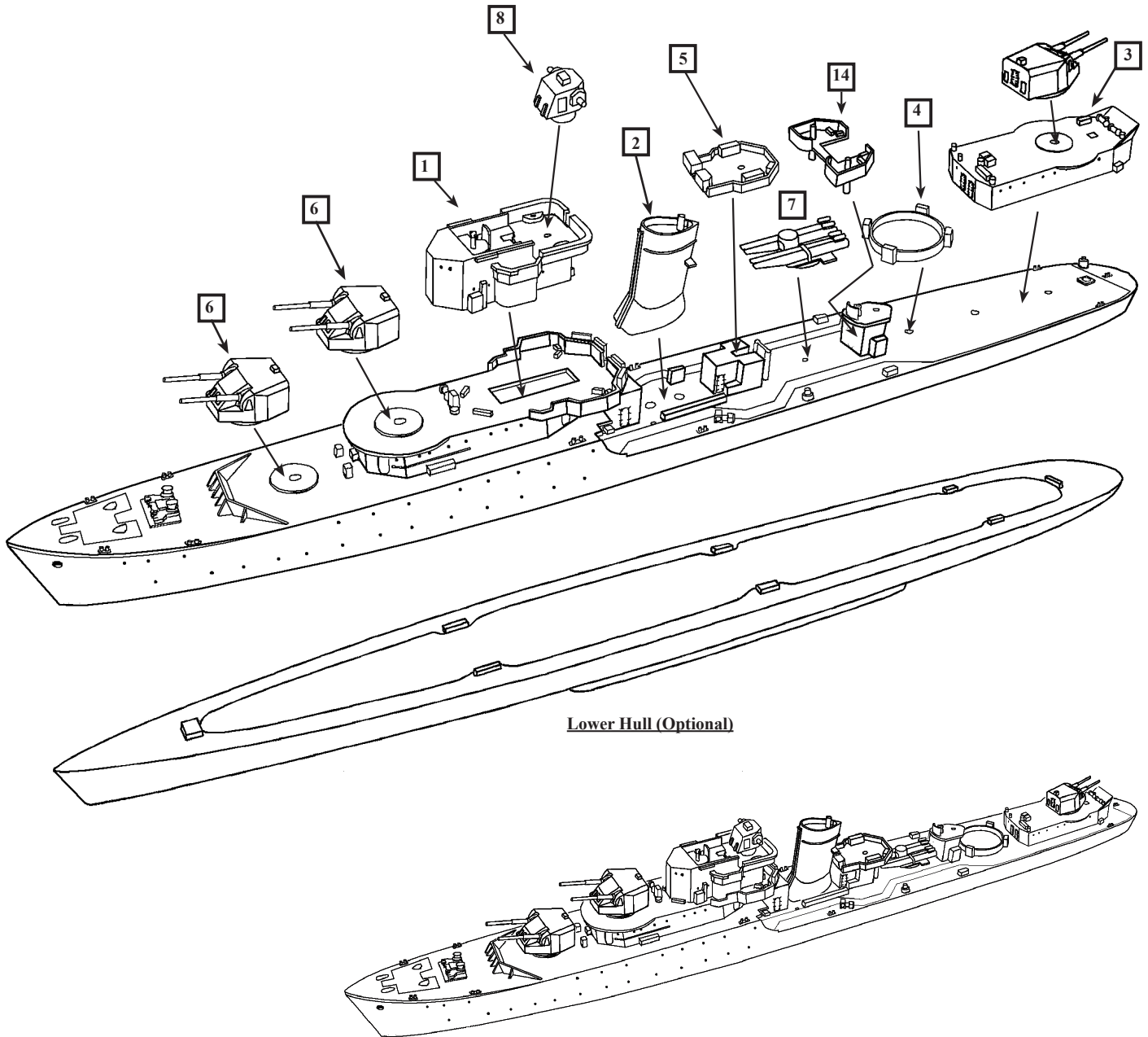

0.5" Quad Machine Gun

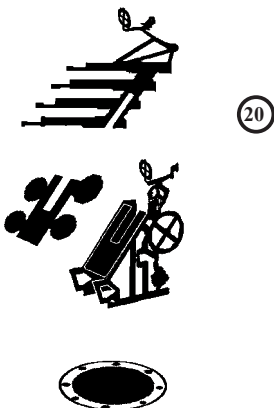

Assemble the half inch quad mounting by folding the side panels of the centre section so that they are parallel.
 Fix down to circular base.
 Fit the offset magazine part, so that they match the slot on the centre section.
 Fit the slot on the barrels section so that it slides over the slot on the centre section, with the barrels facing forwards as shown above. This gun mounting was only fitted early WW2, replaced by 20mm Oerlikons in 1941.

4 Barrelled Pom Pom Assembly

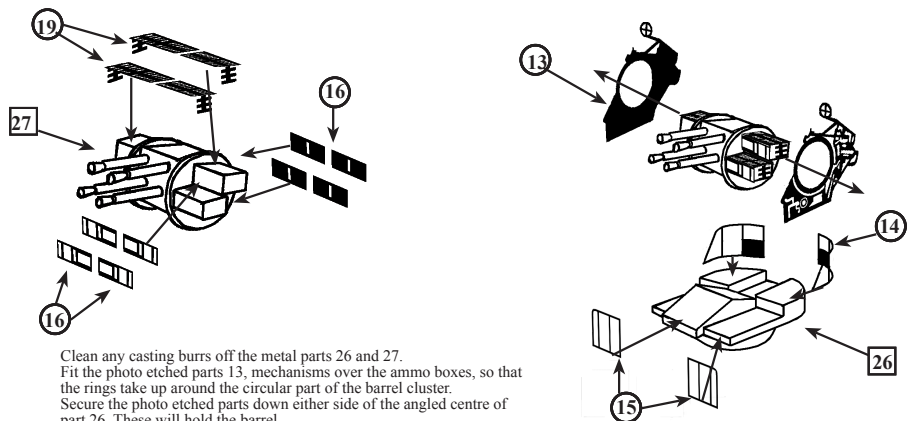

Clean any casting burrs off the metal parts 26 and 27.
 Fit the photo etched parts 13, mechanisms over the ammo boxes, so that the rings take up around the circular part of the barrel cluster.
 Secure the photo etched parts down either side of the angled centre of part 26. These will hold the barrel cluster in place, enabling it to elevate, if the glue has not made contact with the circular area.
 Fit Rear Handrails, etched parts 14, to the rear of the Pom Pom platform and the Front Rails, etched parts 15 as shown.
 Fit completed assembly to the AA Platform, resin part 5, located aft of the funnel.
 Further finer detail may be achieved by removing the soft white metal gun barrels and replacing them with turned brass gun barrels if desired.

Note: The Railings, etched parts 14 and 15 can be substituted by the later fitted splinter shields and mats in the form of etched parts 18 and 17 respectively.

4.7" Gun Turret Assembly

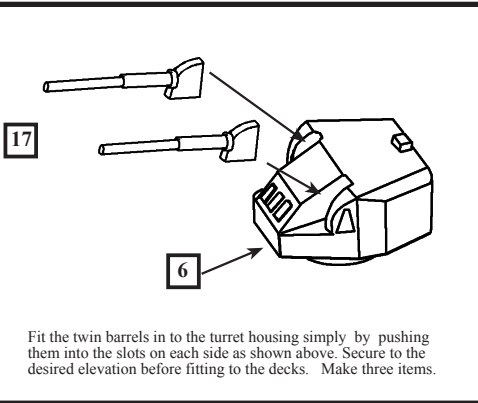

Fit the twin barrels in to the turret housing simply by pushing them into the slots on each side as shown above. Secure to the desired elevation before fitting to the decks. Make three items.

20mm Oerlikon

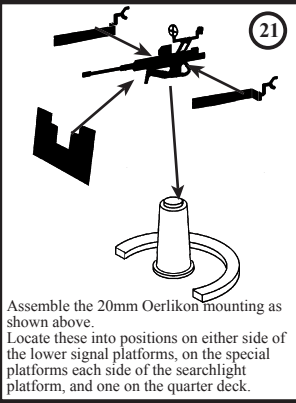

Assemble the 20mm Oerlikon mounting as shown above. Locate these into positions on either side of the lower signal platforms, on the special platforms each side of the searchlight platform, and one on the quarter deck.

4" HA Gun Mounting Assembly

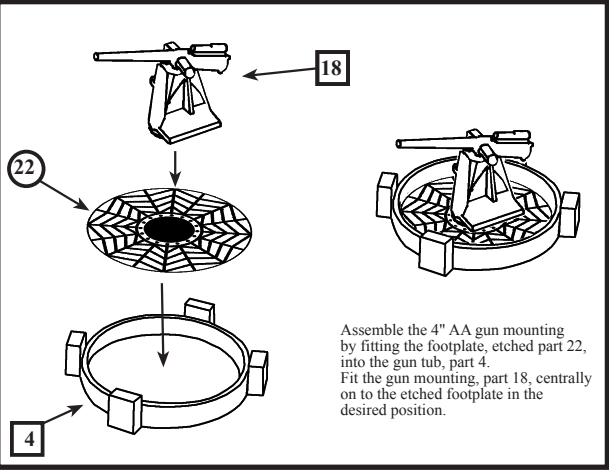

Assemble the 4" AA gun mounting by fitting the footplate, etched part 22, into the gun tub, part 4. Fit the gun mounting, part 18, centrally on to the etched footplate in the desired position.

Boats Assembly

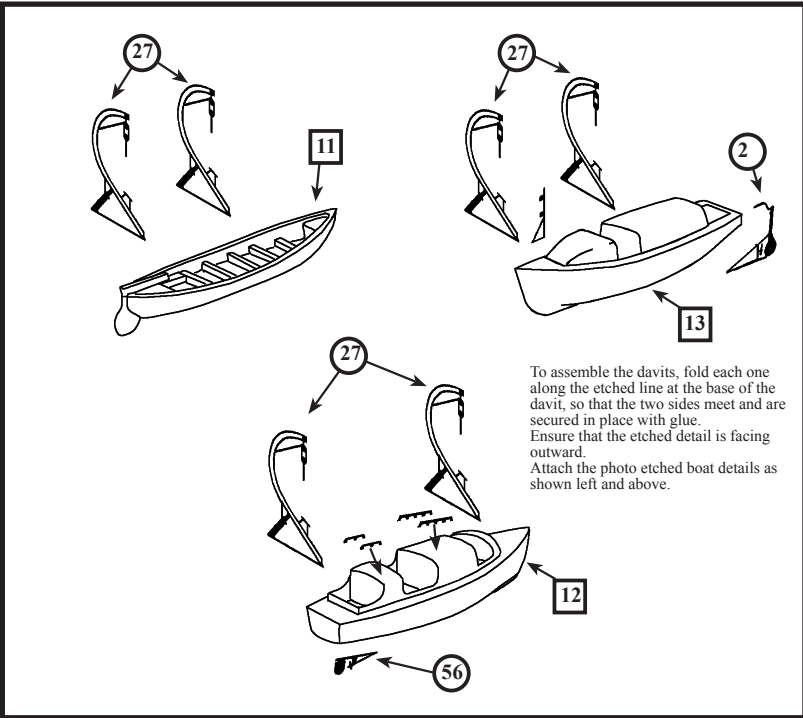

To assemble the davits, fold each one along the etched line at the base of the davit, so that the two sides meet and are secured in place with glue. Ensure that the etched detail is facing outward. Attach the photo etched boat details as shown left and above.

Starboard Side Boat Location

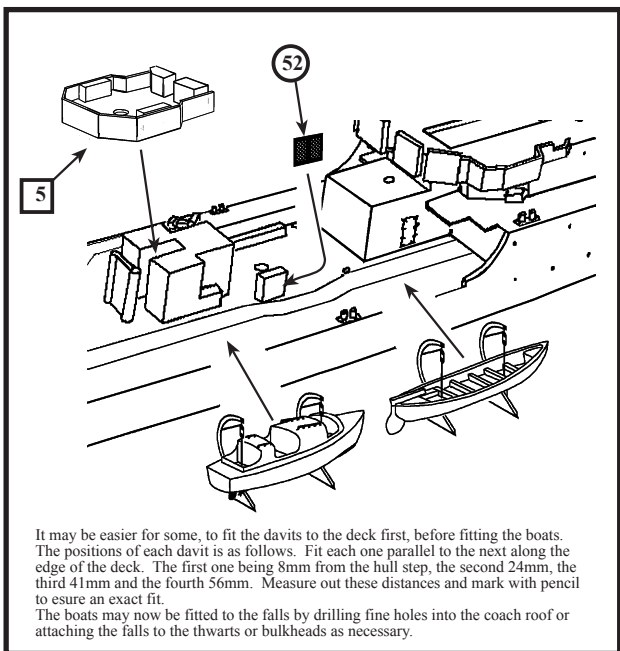

It may be easier for some, to fit the davits to the deck first, before fitting the boats. The positions of each davit is as follows. Fit each one parallel to the next along the edge of the deck. The first one being 8mm from the hull step, the second 24mm, the third 41mm and the fourth 56mm. Measure out these distances and mark with pencil to ensure an exact fit. The boats may now be fitted to the falls by drilling fine holes into the coach roof or attaching the falls to the thwart or bulkheads as necessary.

Port Side Boats Location

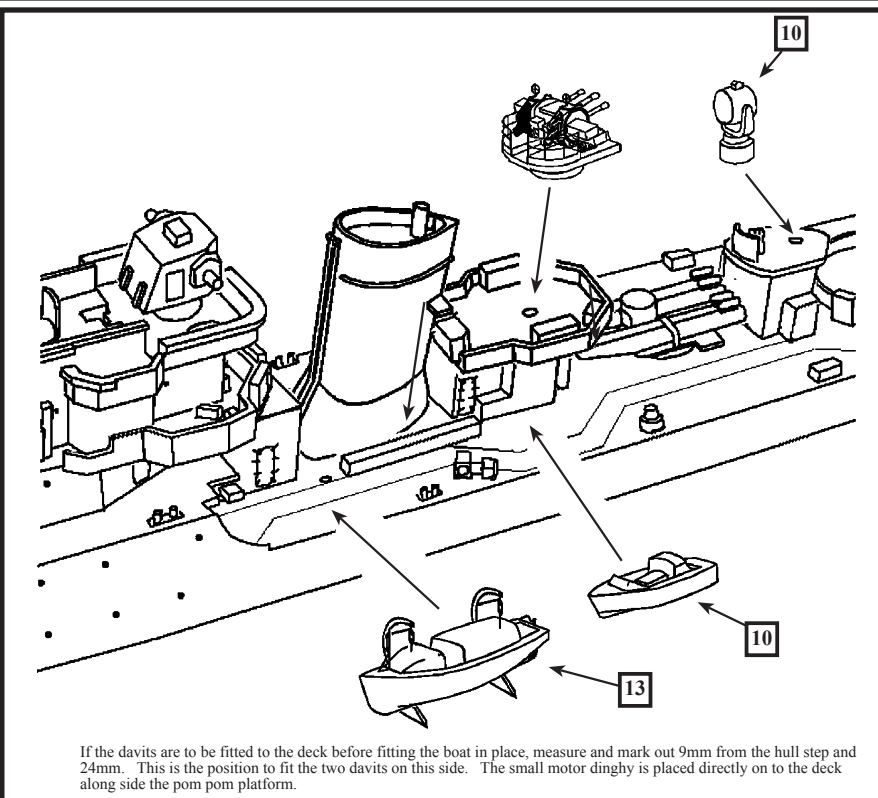

If the davits are to be fitted to the deck before fitting the boat in place, measure and mark out 9mm from the hull step and 24mm. This is the position to fit the two davits on this side. The small motor dinghy is placed directly on to the deck along side the pom pom platform.

Bridge Wing Fittings

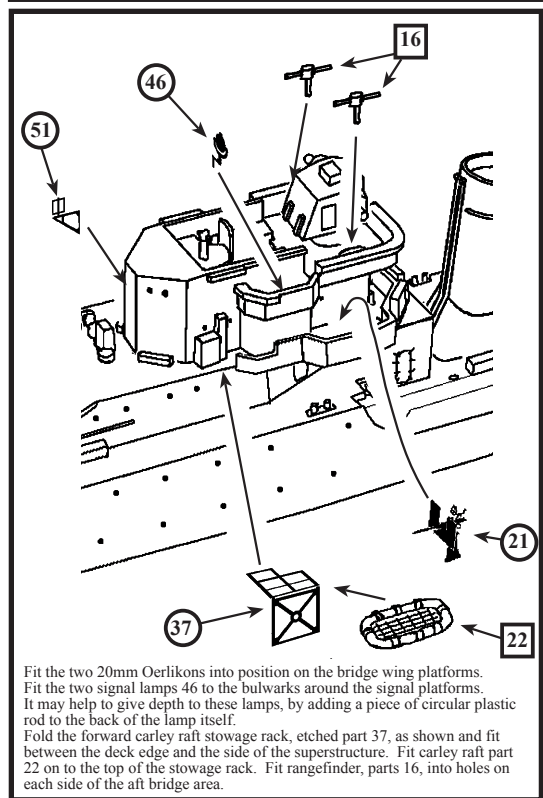

Fit the two 20mm Oerlikons into position on the bridge wing platforms. Fit the two signal lamps 46 to the bulwarks around the signal platforms. It may help to give depth to these lamps, by adding a piece of circular plastic rod to the back of the lamp itself. Fold the forward carley raft stowage rack, etched part 37, as shown and fit between the deck edge and the side of the superstructure. Fit carley raft part 22 on to the top of the stowage rack. Fit rangefinder, parts 16, into holes on each side of the aft bridge area.

Wireless House Location

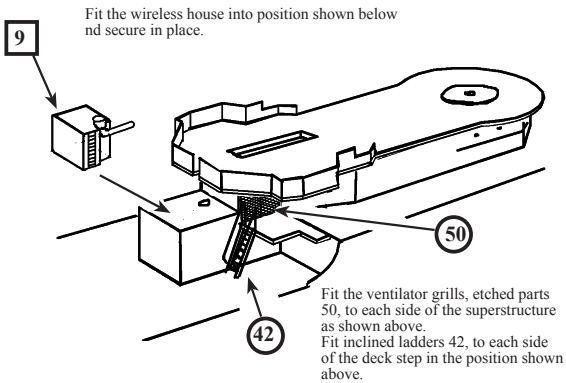

Fit the wireless house into position shown below and secure in place.

Fit the ventilator grills, etched parts 50, to each side of the superstructure as shown above.
Fit inclined ladders 42, to each side of the deck step in the position shown above.

Searchlight Platform Details

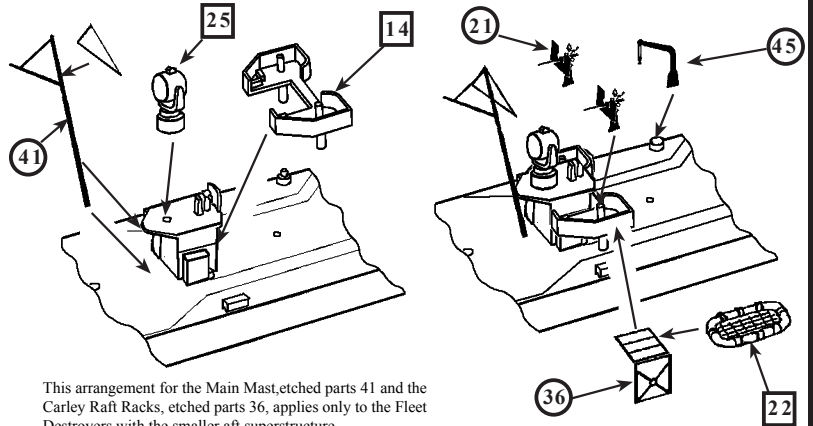

This arrangement for the Main Mast, etched parts 41 and the Carley Raft Racks, etched parts 36, applies only to the Fleet Destroyers with the smaller aft superstructure.

Depth Charge Rails

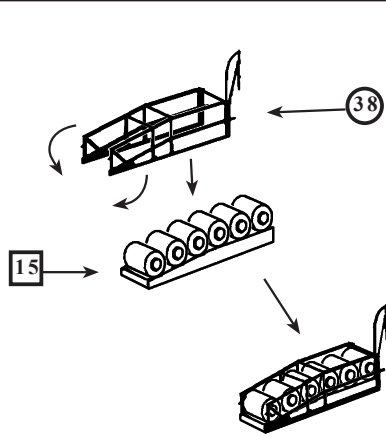

Assemble the depth charge rails by fitting the sides of etched parts 38 down so that they are parallel. Then fit the depth charges on the shuttles, in between as shown above. Repeat on second assembly.

Anchor Assembly

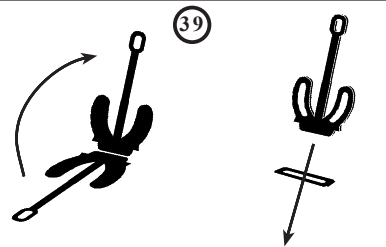

Assemble photo etched anchors 39 as shown above. Fit anchors into the hawse pipes each side of the bow, after first drilling out the holes with a 1.3mm drill bit.

Depth Charge Equipment

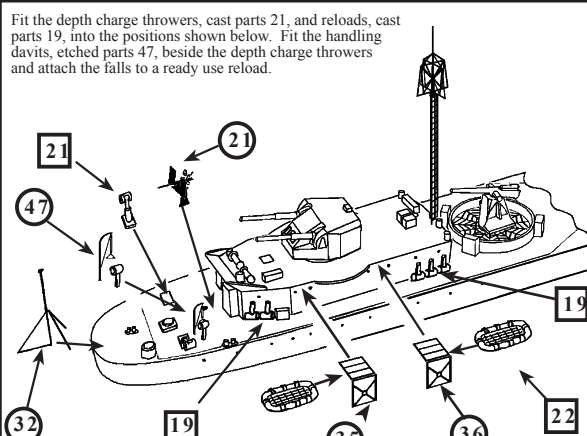

Fit the depth charge throwers, cast parts 21, and reloads, cast parts 19, into the positions shown below. Fit the handling davits, etched parts 47, beside the depth charge throwers and attach the falls to a ready use reload.

Fit 20mm Oerlikon assembly, etched part 21, centrally to the deck just aft of the superstructure. Fold the carley raft racks, etched parts 35 & 36, to 90° and fit between the deck edge and the superstructure just forward of the gun arc overhang on each side. Fit the carley rafts 22 to the top of the racks as shown.

Fit the assembled depth charge rails to the stern positions as shown above. The rails are angled outwards slightly. Refer to the plan view on the colour guide for additional reference.

Fore Mast Assembly

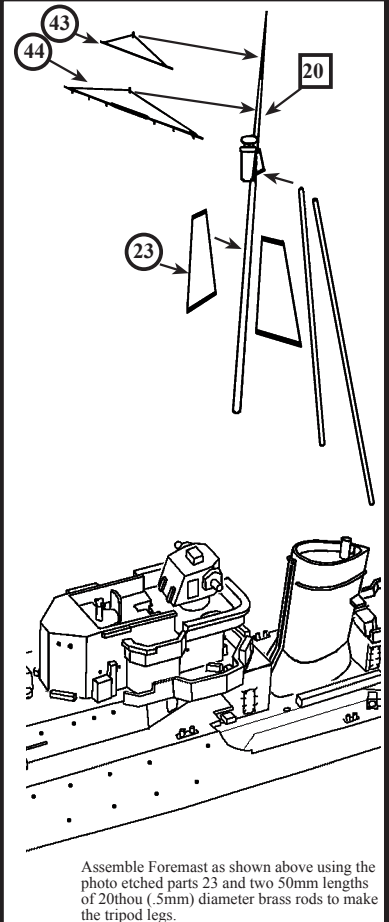

Assemble Foremast as shown above using the photo etched parts 23 and two 50mm lengths of 20thou (.5mm) diameter brass rods to make the tripod legs.

Funnel Fittings

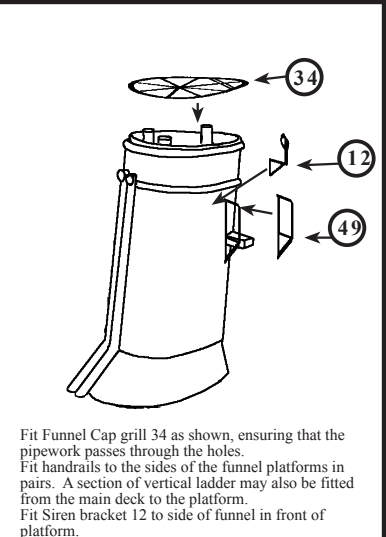

Fit Funnel Cap grill 34 as shown, ensuring that the pipework passes through the holes.
Fit handrails to the sides of the funnel platforms in pairs. A section of vertical ladder may also be fitted from the main deck to the platform.
Fit Siren bracket 12 to side of funnel in front of platform.

286 Radar Antenna

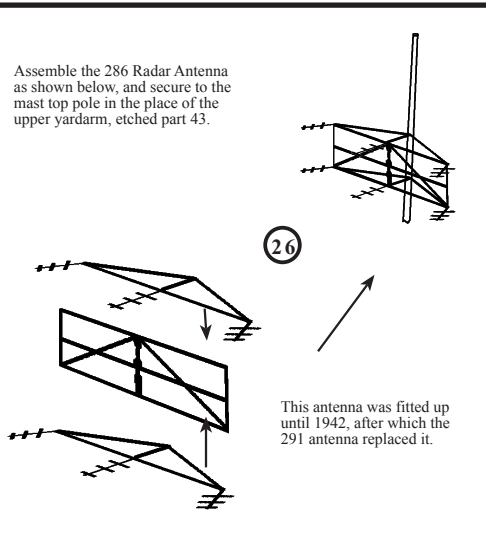

Assemble the 286 Radar Antenna as shown below, and secure to the mast top pole in the place of the upper yardarm, etched part 43.

This antenna was fitted up until 1942, after which the 291 antenna replaced it.

285 Radar Yagi Antenna

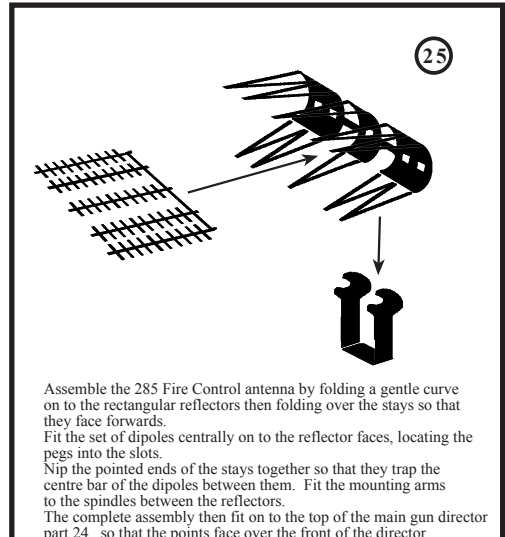

Assemble the 285 Fire Control antenna by folding a gentle curve on to the rectangular reflectors then folding over the stays so that they face forwards.
Fit the set of dipoles centrally on to the reflector faces, locating the pegs into the slots.
Nip the pointed ends of the stays together so that they trap the centre bar of the dipoles between them. Fit the mounting arms to the spindles between the reflectors.
The complete assembly then fit on to the top of the main gun director part 24, so that the points face over the front of the director.

291 Radar Antenna

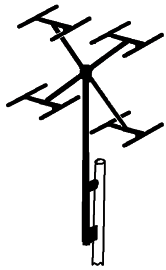

The 291 radar antenna is folded in to shape by bending the outer dipoles so that they face in the direction shown above. This antenna is fitted to the very top of the mast top pole.

MF/DF Antenna

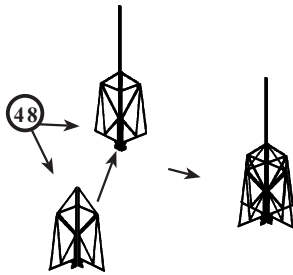

Assemble the MF/DF antenna by folding each of the two halves down the centre line to 90°. Join the halves together by gluing down the centre line and positioning the parts to form a cross when looking from above.

MF/DF Antenna Mast Assembly

Make a pole mast from a length of plastic or brass rod 1.5mm in diameter cut to a length of 35mm. Fit the pole centrally to the forward end of the aft superstructure housing. Place the MF/DF antenna, etched part 48, on top of the pole as shown right. Cut a length of stock vertical ladder, etched part 58, and fit to the starboard side of the pole mast from the deck to the MF/DF antenna.

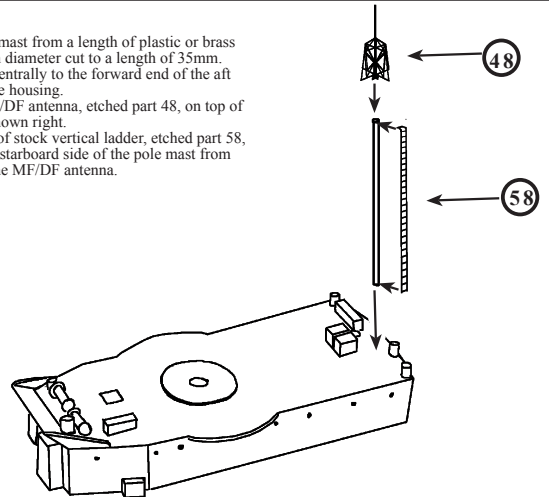

Accommodation Ladder

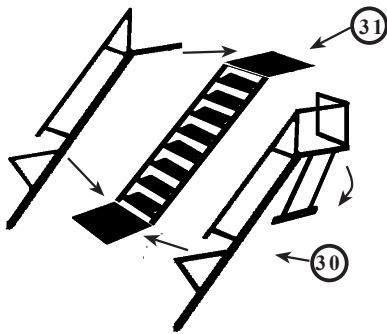

Assemble accommodation ladders as shown above and can be fitted to the ship either side of the main deck, adjacent to the forward end of the aft superstructure, if the ship is to be modelled at anchor. See colour guide for location reference.

Propeller and Rudder Fitting

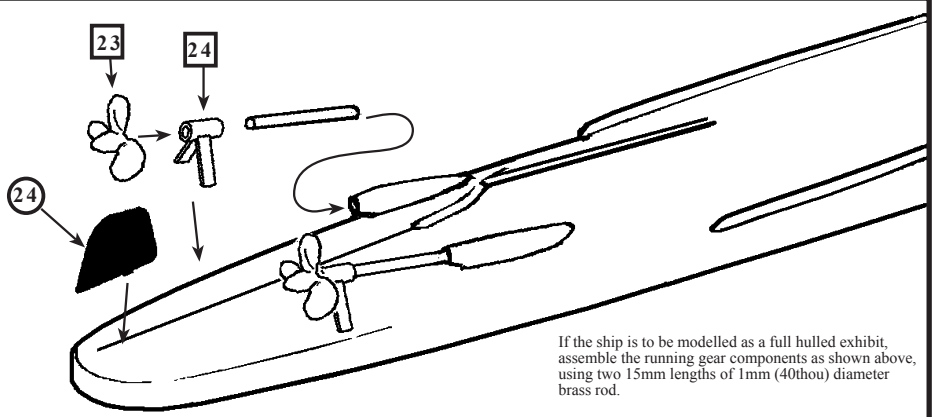

If the ship is to be modelled as a full hulled exhibit, assemble the running gear components as shown above, using two 15mm lengths of 1mm (40thou) diameter brass rod.

Main and Fo'c'sle Deck Railing Location

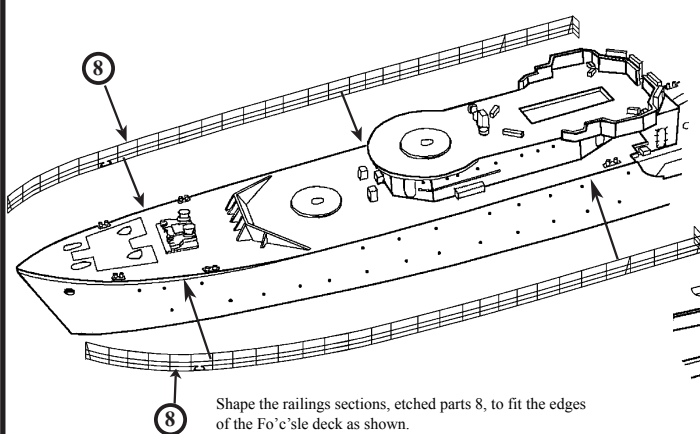

Shape the railings sections, etched parts 8, to fit the edges of the Fo'c'sle deck as shown. The aft end sections are folded inwards to 90° at the first stanchion to meet up with the hull step railings, etched parts 9, when fitted.

Shape the railings sections etched parts 1, to fit the edges of the main deck as shown below, curving them around the stern. Fit the small section of railing, etched part 4, centrally to the stern. There should be a gap on each side of etched part 4, and the ends of etched parts 1, to allow fitting the Depth Charge rails in position.

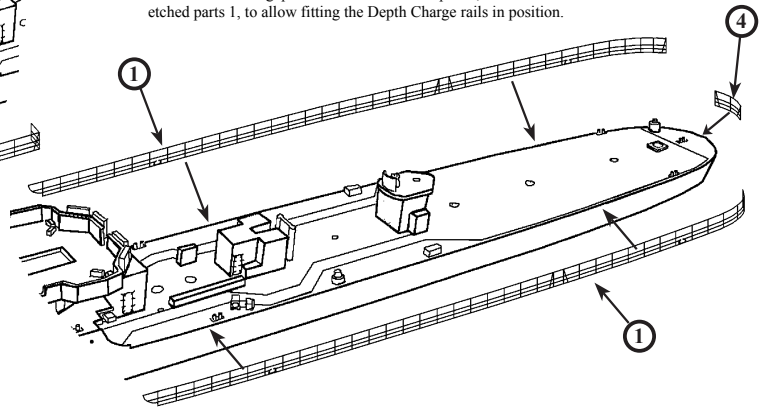

'B' Gun Deck and Hull Step Railings

Gently curve the long section of railings, etched parts 5, to fit around the edge of B gun deck as shown right. Fit the two smaller sections so the aft ends fit against the splinter shields and allow a gap forward for ladder access.

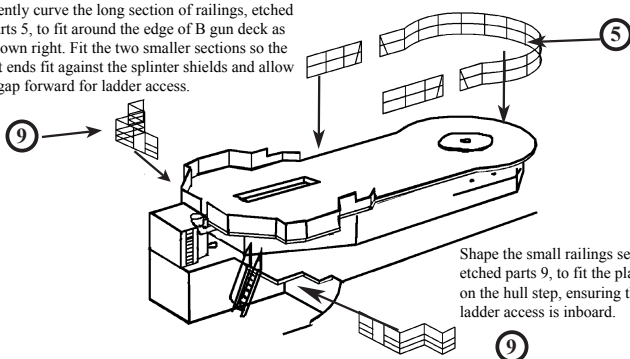

Shape the small railings sections, etched parts 9, to fit the platforms on the hull step, ensuring the small ladder access is inboard.

'X' Gun Deck Railings

Shape and fit the railings sections, etched parts 6 and 7 to the edges of X gun deck as shown below. The longer section, etched part 6 fits to the Port side, which allows a ladder access forward and to the starboard side of the deck.

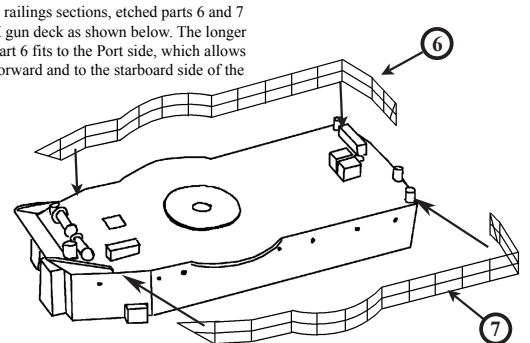

COLOUR CHART & PAINTING GUIDE

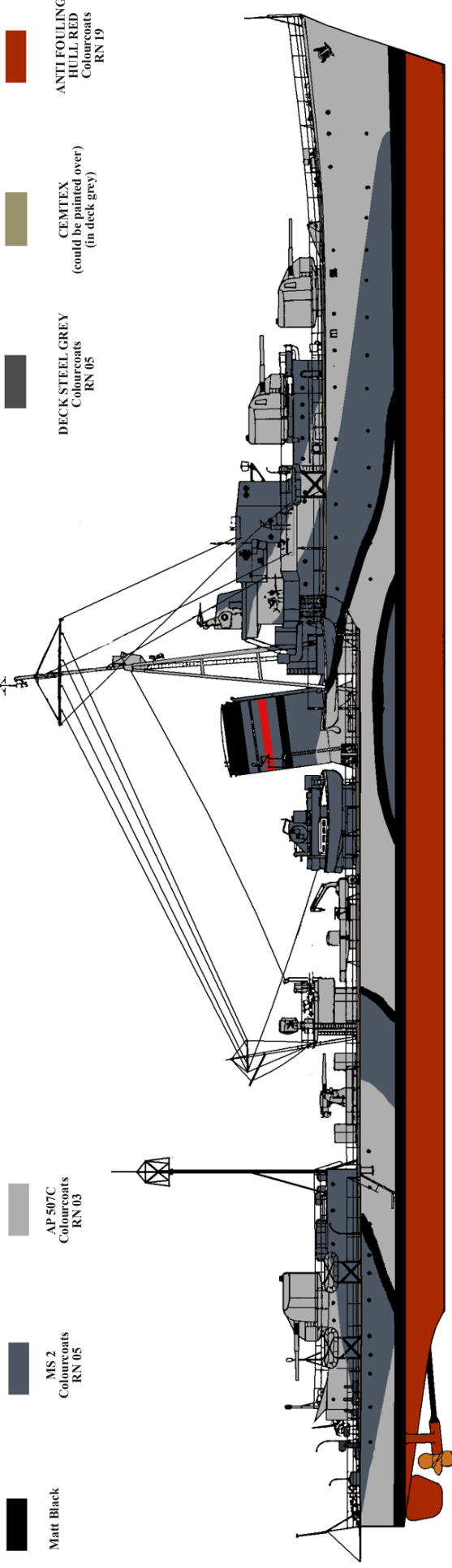

HMS LAFOREY 14th Flotilla Mediterranean June 1943

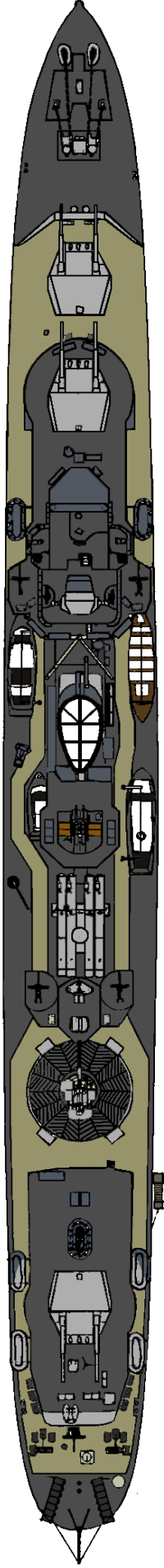

Other Colours: Funnel Top and Cap Grill, Matt Black, Pom Pom and 20mm Oerlikon Barrels, Propellers
 Bronze.

ATLANTIC MODELS © 2016

1 Hillview Grove, Easington, Durham, SR8 3NT, UK Tel. 0191 5271574
 e-mail: peter@atlanticmodels.net Website <http://www.atlanticmodels.net>